

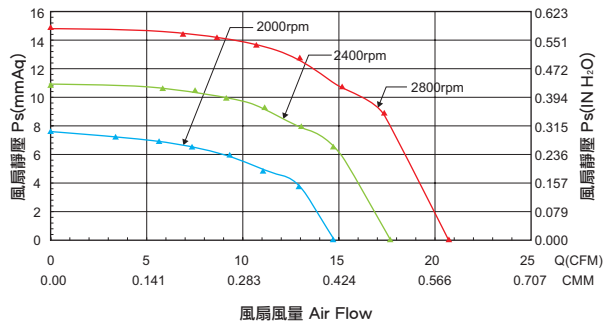

| |
|--|
| Casting and Impeller Material: Plastic (UL 94V-O) |
| Bearing system: Ball Bearing (B) Sleeve Bearing (S) Ball/Sleeve Bearing (SB) |
| Lead Wires: UL 1007 AWG 26 or equivalent. Red:+, Black:-, Sensor: Yellow or White. |
| Model No: X0953212Y X=Bearing system, can be B, SB or S type. Y=Fan speed, can be L, M or H. |
| Options: Auto-restart, FG |
| Net Weight: 143.2g |

Model No. X0953212Y 95×32 mm (3.74"×1.26")

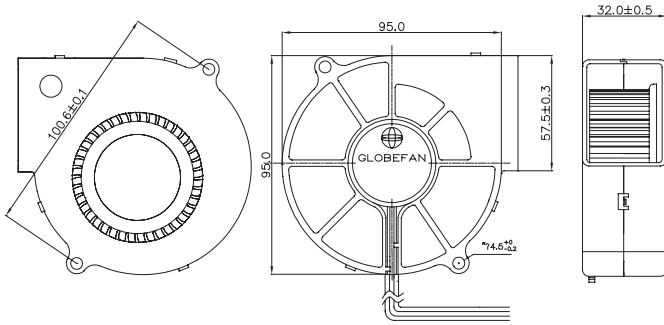

外形圖 外形図 Outline

風量, 靜壓特性曲線
風量, 靜圧特性カーブ
Characteristic Curves

Specifications

| ITEM | | MODEL NO. | X0953212L | X0953212M | X0953212H |
|-----------------------------|----------------------------|-----------|-----------|-----------|-----------|
| RATED VOLTAGE 定格電圧 | 額定電壓 (V) | | 12 | 12 | 12 |
| OPERATING VOLTAGE 動作電圧 | 操縱電壓 (V) | | 6-13.8 | 6-13.8 | 6-13.8 |
| RATED CURRENT 定格電流 | 額定電流 (A) | | 0.2 | 0.3 | 0.5 |
| STARTING VOLTAGE 起動電圧 | 啟動電壓 (V) | | 6 | 6 | 6 |
| RATED INPUT POWER 定格入力 | 額定功率 (W) | | 2.4 | 3.6 | 6.0 |
| MAX AIR FLOW 最大風量 | 最大風量 (CFM) | | 14.80 | 17.70 | 20.70 |
| | 最大風量 (CMM) | | 0.419 | 0.501 | 0.586 |
| MAX STATIC PRESSURE 最大靜壓 | 最大靜壓 (mmAq) | | 7.60 | 11.00 | 15.00 |
| | 最大靜壓 (IN H ₂ O) | | 0.299 | 0.433 | 0.591 |
| NOISE VALUE 騒音値 | 噪音值 (dBA) | | 36.0 | 41.4 | 45.1 |
| RATED SPEED 回轉數 | 額定轉速 (rpm ± 10%) | | 2000 | 2400 | 2800 |