

DC LED Fan / 8CM



Model No.

RLXX Y0801512Z 80x80x15mm

Frame and Impeller Material :
Plastic (UL 94V-O)

Bearing system :
Ball Bearing (B)
Sleeve Bearing (S)

Lead Wires :
UL 1007 AWG 28 or equivalent.
Red:+, Black:-

Model No. :

RLXX Y0801512ZG

XX= 0~9 or A~Z

Y=Bearing system, can be B or S type.

Z=Fan speed, can be L, M or H.

Net Weight :

50g

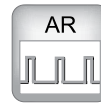

OUTLINE

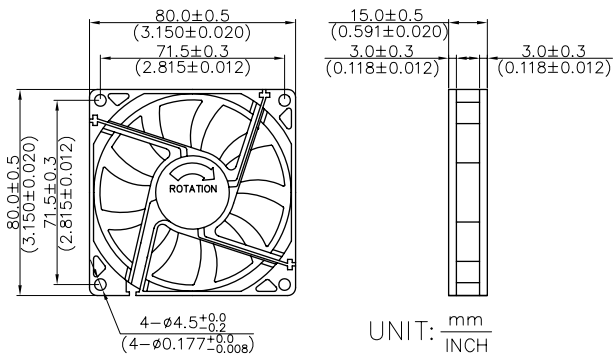

CHARACTERISTIC CURVES

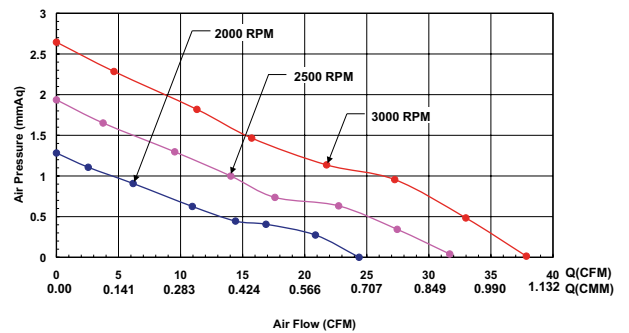

SPECIFICATIONS

Item Model No.	Rated Voltage	Operating Voltage Range	Rated Current	Starting Voltage	Rated Input Power	Max Air Flow		Max Air Pressure		Noise	Speed
	V _{DC}	V _{DC}	A	V _{DC}	W	CMM	CFM	mmAq	inAq	dBA	RPM±10%
RLXX Y0801512L	12	6~13.8	0.19	6	2.28	0.69	24.38	1.28	0.05	20.9	2000
RLXX Y0801512M	12	6~13.8	0.23	6	2.76	0.90	31.68	1.94	0.08	29.4	2500
RLXX Y0801512H	12	6~13.8	0.27	6	3.24	1.07	37.86	2.65	0.10	31.3	3000