

DC Axial Fan / 8CM



Model No.

X0801512Y 80x80x15mm

Frame and Impeller Material :
Plastic (UL 94V-O)

Bearing system :
Ball Bearing (B)
Sleeve Bearing (S)

Lead Wires :
UL 1007 AWG 28 or equivalent.
Red:+, Black:-

Model No. :
X0801512Y

X=Bearing system, can be B or S type..
Y=Fan speed, can be L, M, H or HH.

Net Weight :
55g

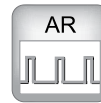

OUTLINE

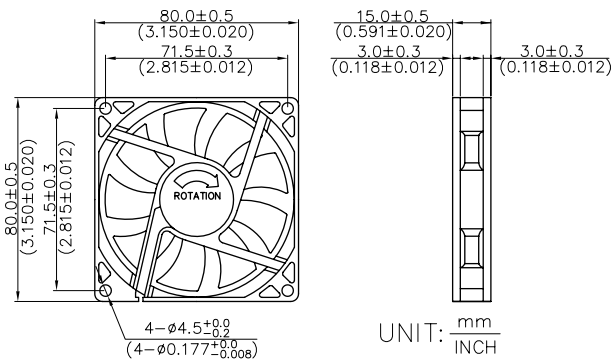

CHARACTERISTIC CURVES

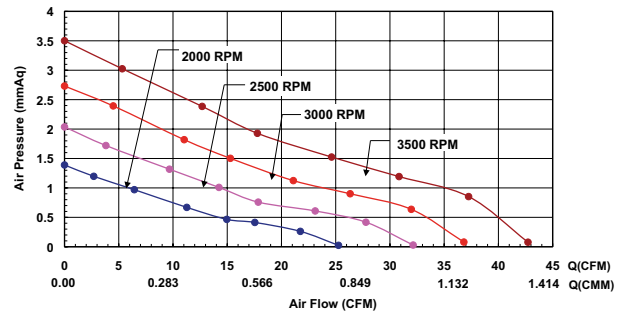

SPECIFICATIONS

Item	Rated Voltage	Operating Voltage Range	Rated Current	Starting Voltage	Rated Input Power	Max Air Flow		Max Air Pressure		Noise	Speed
	V _{DC}	V _{DC}	A	V _{DC}	W	CMM	CFM	mmAq	inAq	dBA	RPM±10%
X0801512L	12	6~13.8	0.11	6	1.32	0.72	25.26	1.39	0.05	20.4	2000
X0801512M	12	6~13.8	0.13	6	1.56	0.91	32.14	2.04	0.08	25.5	2500
X0801512H	12	6~13.8	0.19	6	2.28	1.04	36.81	2.73	0.11	30.3	3000
X0801512HH	12	6~13.8	0.19	6	2.28	1.21	42.73	3.50	0.14	34.1	3500