

# DC Axial Fan / 7CM



Model No.

**X0701512Y** 70x70x15mm

Frame and Impeller Material :  
Plastic (UL 94V-O)

Bearing system :  
Ball Bearing (B)  
Sleeve Bearing (S)

Lead Wires :  
UL 1007 AWG 28 or equivalent.  
Red:+, Black:-

Model No. :  
X0701512Y

X=Bearing system, can be B or S type..  
Y=Fan speed, can be LL, L, or M.

Net Weight :  
46.5g

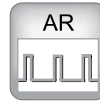

## OUTLINE

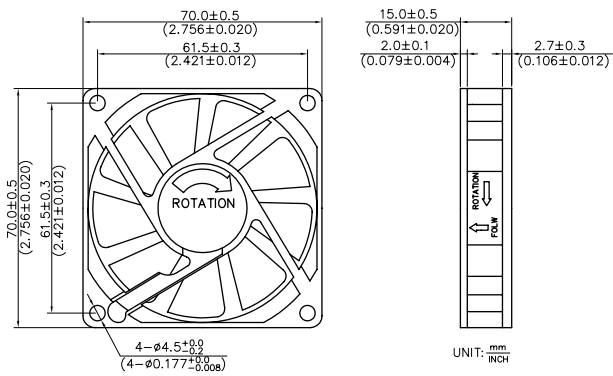

## CHARACTERISTIC CURVES

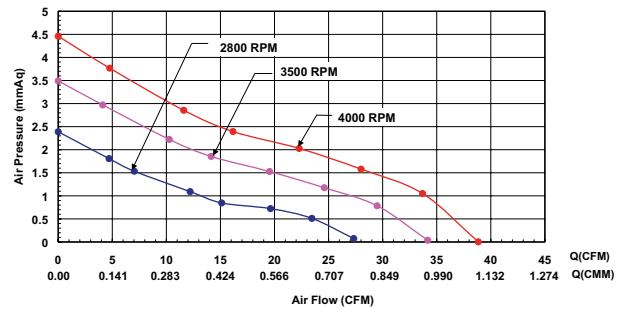

## SPECIFICATIONS

Item Model No.	Rated Voltage	Operating Voltage Range	Rated Current	Starting Voltage	Rated Input Power	Max Air Flow		Max Air Pressure		Noise	Speed
	V <sub>DC</sub>	V <sub>DC</sub>	A	V <sub>DC</sub>	W	CMM	CFM	mmAq	inAq	dBA	RPM±10%
X0701512LL	12	6~13.8	0.20	6	2.40	0.77	27.32	2.38	0.09	29.8	2800
X0701512L	12	6~13.8	0.20	6	2.40	0.97	34.16	3.49	0.14	33.6	3500
X0701512M	12	6~13.8	0.30	6	3.60	1.10	38.84	4.45	0.18	36.3	4000