



Model No.

X0602012Y

60x60x20mm

Frame and Impeller Material :
Plastic (UL 94V-O)

Bearing system :
Ball Bearing (B)
Sleeve Bearing (S)

Lead Wires :
UL 1007 AWG 28 or equivalent.
Red:+, Black:-

Model No. :
X0602012Y

X=Bearing system, can be B or S type..
Y=Fan speed, can be L, M, H or HH.

Net Weight :
52g

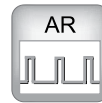

OUTLINE

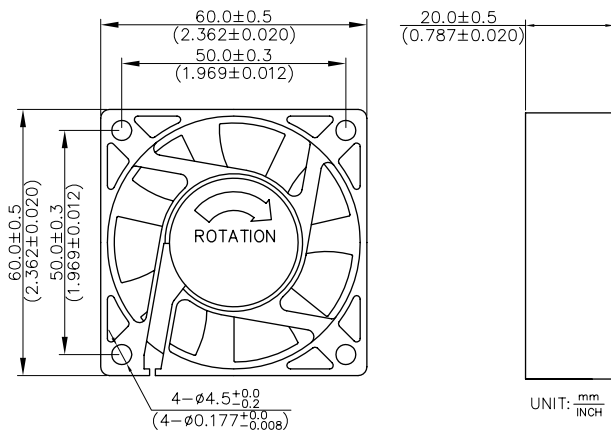

CHARACTERISTIC CURVES

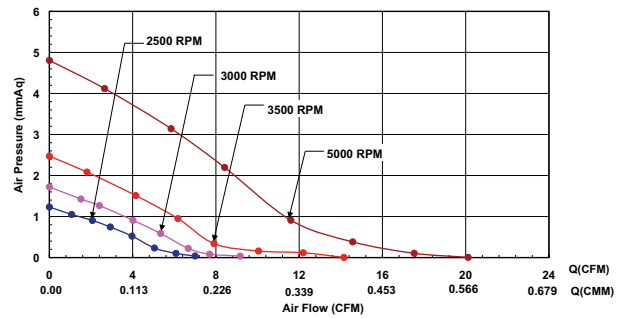

SPECIFICATIONS

Item	Rated Voltage	Operating Voltage Range	Rated Current	Starting Voltage	Rated Input Power	Max Air Flow		Max Air Pressure		Noise	Speed
	V _{DC}	V _{DC}	A	V _{DC}	W	CMM	CFM	mmAq	inAq	dBA	RPM±10%
X0602012L	12	6~13.8	0.08	6	0.10	0.20	7.00	1.23	0.05	20.8	2500
X0602012M	12	6~13.8	0.10	6	1.20	0.26	9.17	1.72	0.07	23.6	3000
X0602012H	12	6~13.8	0.15	6	1.80	0.40	14.15	2.47	0.10	27.1	3500
X0602012HH	12	6~13.8	0.20	6	2.40	0.57	20.12	4.81	0.19	36.3	5000